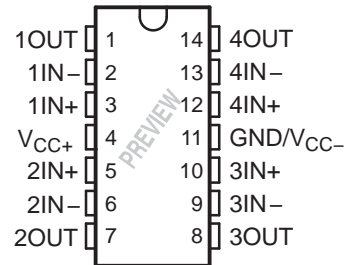
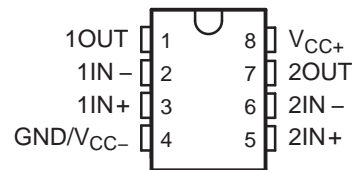
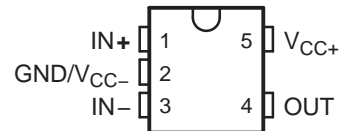

## LOW-VOLTAGE RAIL-TO-RAIL OUTPUT OPERATIONAL AMPLIFIERS

### FEATURES

- Qualified for Automotive Applications
- 2.5-V, 2.7-V, and 5-V Performance
- –40°C to 125°C Operation
- No Crossover Distortion
- Low Supply Current at  $V_{CC+} = 5\text{ V}$ :
  - LMV821...0.3 mA Typ
  - LMV822...0.5 mA Typ
  - LMV824...1 mA Typ
- Rail-to-Rail Output Swing
- Gain Bandwidth of 5.5 MHz Typ at 5 V
- Slew Rate of 1.9 V/μs Typ at 5 V

**LMV824 . . . D, DGV, OR PW PACKAGE  
(TOP VIEW)**

**LMV822 . . . D OR DGK PACKAGE  
(TOP VIEW)**

**LMV821 . . . DBV OR DCK PACKAGE  
(TOP VIEW)**

### DESCRIPTION/ORDERING INFORMATION

The LMV821 single, LMV822 dual, and LMV824 quad devices are low-voltage (2.5 V to 5.5 V), low-power commodity operational amplifiers. Electrical characteristics are very similar to the LMV3xx operational amplifiers (low supply current, rail-to-rail outputs, input common-mode range, which includes ground). However, the LMV8xx devices offer a higher bandwidth (5.5 MHz typical) and faster slew rate (1.9 V/μs typical).

The LMV8xx devices are cost-effective solutions for applications requiring low-voltage/low-power operation and space-saving considerations. The LMV821 is available in the ultra-small DCK package, which is approximately half the size of SOT-23-5. The DCK package saves space on printed circuit boards and enables the design of small portable electronic devices (cordless and cellular phones, laptops, PDAs, PC/MIA). It also allows the designer to place the device closer to the signal source to reduce noise pickup and increase signal integrity.

The LMV8xx-Q1 devices are characterized for operation from –40°C to 125°C.



Please be aware that an important notice concerning availability, standard warranty, and use in critical applications of Texas Instruments semiconductor products and disclaimers thereto appears at the end of this data sheet.

**ORDERING INFORMATION<sup>(1)</sup>**

| T <sub>A</sub> | PACKAGE <sup>(2)</sup> |                  | ORDERABLE PART NUMBER | TOP-SIDE MARKING <sup>(3)</sup> |         |
|----------------|------------------------|------------------|-----------------------|---------------------------------|---------|
| -40°C to 125°C | Single                 | SC-70 – DCK      | Reel of 3000          | LMV821QDCKRQ1                   | PREVIEW |
|                |                        | SOT-23 – DBV     | Reel of 3000          | LMV821QDBVRQ1                   | RB1_    |
|                | Dual                   | SOIC – D         | Reel of 2500          | LMV822QDRQ1                     | PREVIEW |
|                |                        | MSOP/VSSOP – DGK | Reel of 2500          | LMV822QDGKRQ1                   | R8B     |
|                | Quad                   | SOIC – D         | Reel of 2500          | LMV824QDRQ1                     | PREVIEW |
|                |                        | TSSOP – PW       | Reel of 2000          | LMV824QPWRQ1                    | PREVIEW |
| TVSOP – DGV    |                        | Reel of 2000     | LMV824QDGVRQ1         | PREVIEW                         |         |

- (1) For the most current package and ordering information, see the Package Option Addendum at the end of this document, or see the TI web site at [www.ti.com](http://www.ti.com).
- (2) Package drawings, thermal data, and symbolization are available at [www.ti.com/packaging](http://www.ti.com/packaging).
- (3) DBV/DCK: The actual top-side marking has one additional character that designates the wafer fab/assembly site.

**SYMBOL (EACH AMPLIFIER)**

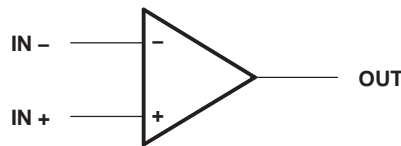

**LMV824 SIMPLIFIED SCHEMATIC**

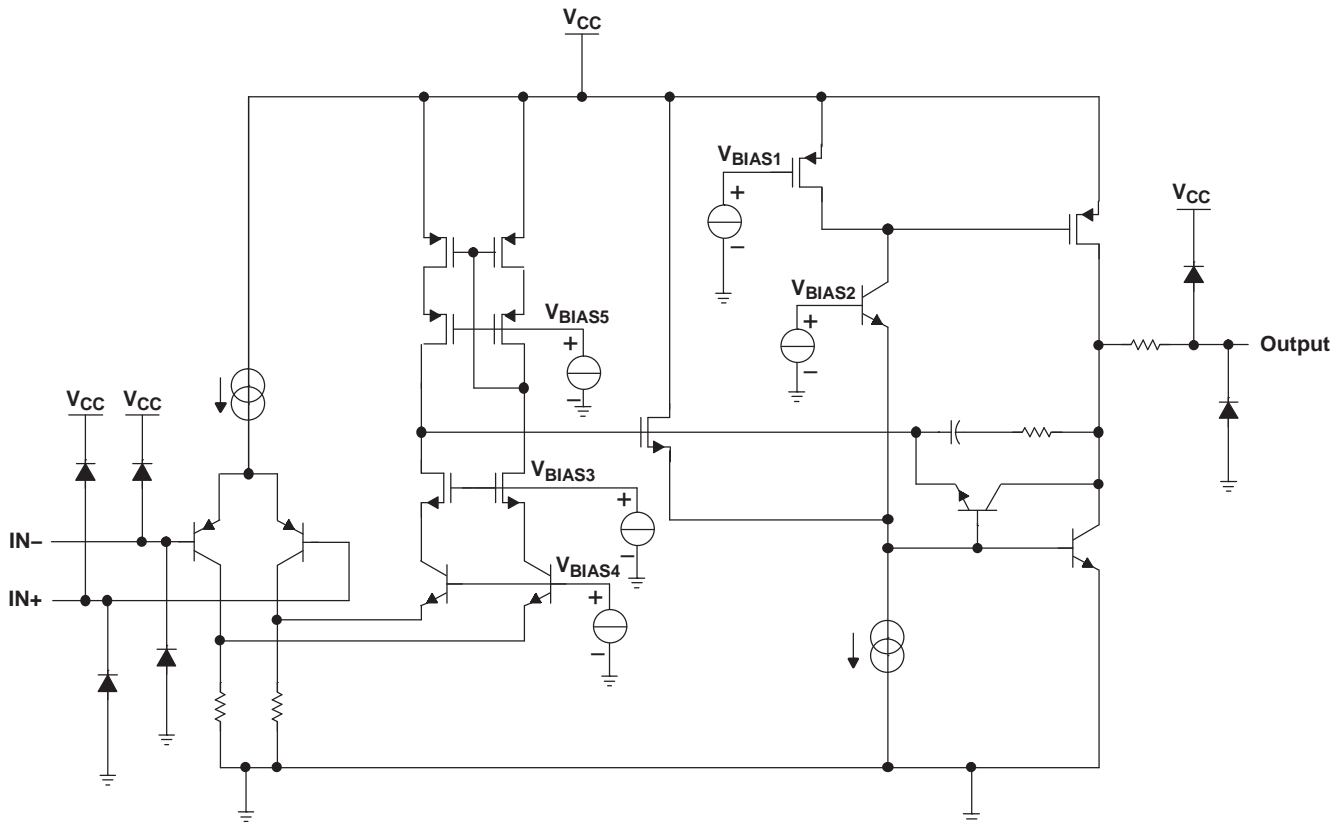

## Absolute Maximum Ratings<sup>(1)</sup>

over operating free-air temperature range (unless otherwise noted)

|   |   | MIN   | MAX          | UNIT      |      |
|---|---|---|--------------|-----------|------|
| $V_{CC}$  | Supply voltage <sup>(2)</sup>               |   | 5.5          | V         |      |
| $V_{ID}$  | Differential input voltage <sup>(3)</sup>   |   | $\pm V_{CC}$ | V         |      |
| $V_I$   | Input voltage range (either input)          | $V_{CC-}$   | $V_{CC+}$    | V         |      |
| Duration of output short circuit (one amplifier) to ground <sup>(4)</sup> |   | At or below $T_A = 25^\circ\text{C}$ , $V_{CC} \leq 5.5\text{ V}$ |              | Unlimited |      |
| $\theta_{JA}$   | Package thermal impedance <sup>(5)(6)</sup> | D package   | 8 pin        | 97        | °C/W |
|   |   |   | 14 pin       | 86        |      |
|   |   | DBV package   | 206          |           |      |
|   |   | DCK package   | 252          |           |      |
|   |   | DGK package   | 172          |           |      |
|   |   | DGV package   | 127          |           |      |
|   |   | PW package  | 113          |           |      |
| $T_J$   | Operating virtual junction temperature      |   | 150          | °C        |      |
| $T_{stg}$   | Storage temperature range                   | -65   | 150          | °C        |      |

- (1) Stresses beyond those listed under “absolute maximum ratings” may cause permanent damage to the device. These are stress ratings only, and functional operation of the device at these or any other conditions beyond those indicated under “recommended operating conditions” is not implied. Exposure to absolute-maximum-rated conditions for extended periods may affect device reliability.
- (2) All voltage values (except differential voltages and  $V_{CC}$  specified for the measurement of  $I_{OS}$ ) are with respect to the network GND.
- (3) Differential voltages are at IN+ with respect to IN-.
- (4) Short circuits from outputs to  $V_{CC}$  can cause excessive heating and eventual destruction.
- (5) Maximum power dissipation is a function of  $T_J(\text{max})$ ,  $\theta_{JA}$ , and  $T_A$ . The maximum allowable power dissipation at any allowable ambient temperature is  $P_D = (T_J(\text{max}) - T_A)/\theta_{JA}$ . Operating at the absolute maximum  $T_J$  of 150°C can affect reliability.
- (6) The package thermal impedance is calculated in accordance with JESD 51-7.

## Recommended Operating Conditions

|          |  | MIN | MAX | UNIT |
|----------|--|-----|-----|------|
| $V_{CC}$ | Supply voltage (single-supply operation) | 2.5 | 5   | V    |
| $T_A$    | Operating free-air temperature           | -40 | 125 | °C   |

## 2.5-V Electrical Characteristics

 $V_{CC+} = 2.5\text{ V}$ ,  $V_{CC-} = 0\text{ V}$ ,  $V_{IC} = 1\text{ V}$ ,  $V_O = 1.25\text{ V}$ , and  $R_L > 1\text{ M}\Omega$  (unless otherwise noted)

| PARAMETER | TEST CONDITIONS      |   | $T_A$          | MIN            | TYP  | MAX  | UNIT |      |
|-----------|----------------------|---|----------------|----------------|------|------|------|------|
| $V_{IO}$  | Input offset voltage |   | 25°C           |                | 1    | 6    | mV   |      |
|           |                      |   | -40°C to 125°C |                |      | 6    |      |      |
| $V_O$     | Output swing         | $V_{CC+} = 2.5\text{ V}$ , $R_L = 600\ \Omega$ to 1.25 V      | High level     | 25°C           | 2.28 | 2.37 | V    |      |
|           |                      |   |                | -40°C to 125°C | 2.18 |      |      |      |
|           |                      |   | Low level      | 25°C           |      | 0.13 |      | 0.22 |
|           |                      |   |                | -40°C to 125°C |      |      |      | 0.32 |
|           |                      | $V_{CC+} = 2.5\text{ V}$ , $R_L = 2\text{ k}\Omega$ to 1.25 V | High level     | 25°C           | 2.38 | 2.46 |      |      |
|           |                      |   |                | -40°C to 125°C | 2.28 |      |      |      |
|           |                      |   | Low level      | 25°C           |      | 0.08 |      | 0.14 |
|           |                      |   |                | -40°C to 125°C |      |      |      | 0.22 |

**2.7-V Electrical Characteristics**

$V_{CC+} = 2.7\text{ V}$ ,  $V_{CC-} = 0\text{ V}$ ,  $V_{IC} = 1\text{ V}$ ,  $V_O = 1.35\text{ V}$ , and  $R_L > 1\text{ M}\Omega$  (unless otherwise noted)

| PARAMETER  |   | TEST CONDITIONS  |          | $T_A$          | MIN            | TYP            | MAX  | UNIT                         |     |
|--|---|--|----------|----------------|----------------|----------------|------|------------------------------|-----|
| $V_{IO}$   | Input offset voltage                                    |  |          | 25°C           |                | 1              | 6    | mV                           |     |
|  |   |  |          | -40°C to 125°C |                |                | 6    |                              |     |
| $\alpha_{VIO}$   | Average temperature coefficient of input offset voltage |  |          | 25°C           |                | 1              |      | $\mu\text{V}/^\circ\text{C}$ |     |
| $I_{IB}$   | Input bias current                                      |  |          | 25°C           |                | 30             | 90   | nA                           |     |
|  |   |  |          | -40°C to 125°C |                |                | 140  |                              |     |
| $I_{IO}$   | Input offset current                                    |  |          | 25°C           |                | 0.5            | 30   | nA                           |     |
|  |   |  |          | -40°C to 125°C |                |                | 50   |                              |     |
| CMRR   | Common-mode rejection ratio                             | $V_{IC} = 0\text{ to }1.7\text{ V}$  |          | 25°C           | 70             | 85             |      | dB                           |     |
|  |   |  |          | -40°C to 125°C | 68             |                |      |                              |     |
| $+k_{SVR}$   | Positive supply-voltage rejection ratio                 | $V_{CC+} = 1.7\text{ V to }4\text{ V}$ , $V_{CC-} = -1\text{ V}$ , $V_O = 0$ , $V_{IC} = 0$    |          | 25°C           | 75             | 85             |      | dB                           |     |
|  |   |  |          | -40°C to 125°C | 70             |                |      |                              |     |
| $-k_{SVR}$   | Negative supply-voltage rejection ratio                 | $V_{CC+} = 1.7\text{ V}$ , $V_{CC-} = -1\text{ V to }-3.3\text{ V}$ , $V_O = 0$ , $V_{IC} = 0$ |          | 25°C           | 73             | 85             |      | dB                           |     |
|  |   |  |          | -40°C to 125°C | 70             |                |      |                              |     |
| $V_{ICR}$  | Common-mode input voltage range                         | CMRR $\geq 50\text{ dB}$   |          | 25°C           | -0.2 to 1.9    | -0.3 to 2      |      | V                            |     |
| $A_V$  | Large-signal voltage amplification                      | $R_L = 600\ \Omega\text{ to }1.35\text{ V}$ , $V_O = 1.35\text{ V to }2.2\text{ V}$            | Sourcing | 25°C           | 90             | 100            |      | dB                           |     |
|  |   |  |          | -40°C to 125°C | 85             |                |      |                              |     |
|  |   | $R_L = 600\ \Omega\text{ to }1.35\text{ V}$ , $V_O = 1.35\text{ V to }0.5\text{ V}$            | Sinking  | 25°C           | 85             | 90             |      |                              |     |
|  |   |  |          | -40°C to 125°C | 80             |                |      |                              |     |
| $R_L = 2\text{ k}\Omega\text{ to }1.35\text{ V}$ , $V_O = 1.35\text{ V to }2.2\text{ V}$ | Sourcing  | 25°C   | 95       | 100            |                |                |      |                              |     |
|  |   | -40°C to 125°C   | 90       |                |                |                |      |                              |     |
| $R_L = 2\text{ k}\Omega\text{ to }1.35\text{ V}$ , $V_O = 1.35\text{ V to }0.5\text{ V}$ | Sinking   | 25°C   | 90       | 95             |                |                |      |                              |     |
|  |   | -40°C to 125°C   | 85       |                |                |                |      |                              |     |
| $V_O$  | Output swing  | $V_{CC+} = 2.7\text{ V}$ , $R_L = 600\ \Omega\text{ to }1.35\text{ V}$                         |          | High level     | 25°C           | 2.5            | 2.58 |                              | V   |
|  |   |  |          |                |                | -40°C to 125°C | 2.4  |                              |     |
|  |   |  |          | Low level      | 25°C           |                | 0.13 | 0.2                          |     |
|  |   |  |          |                | -40°C to 125°C |                |      | 0.3                          |     |
|  |   | $V_{CC+} = 2.7\text{ V}$ , $R_L = 2\text{ k}\Omega\text{ to }1.35\text{ V}$                    |          | High level     | 25°C           | 2.6            | 2.66 |                              |     |
|  |   |  |          |                |                | -40°C to 125°C | 2.5  |                              |     |
| Low level  | 25°C  |  | 0.08     | 0.12           |                |                |      |                              |     |
|  | -40°C to 125°C  |  |          | 0.2            |                |                |      |                              |     |
| $I_O$  | Output current  | $V_O = 0\text{ V}$   | Sourcing | 25°C           | 12             | 16             |      | mA                           |     |
|  |   | $V_O = 2.7\text{ V}$   | Sinking  | 25°C           | 12             | 26             |      |                              |     |
| $I_{CC}$   | Supply current  | LMV821   |          | 25°C           |                | 0.22           | 0.3  | mA                           |     |
|  |   |  |          |                | -40°C to 125°C |                |      |                              | 0.5 |
|  |   | LMV822 (both amplifiers)   |          | 25°C           |                | 0.45           | 0.6  |                              |     |
|  |   |  |          |                | -40°C to 125°C |                |      |                              | 0.8 |
|  |   | LMV824 (all four amplifiers)   |          | 25°C           |                | 0.72           | 1    |                              |     |
|  |   |  |          |                | -40°C to 125°C |                |      |                              | 1.2 |

**2.7-V Electrical Characteristics (continued)**
 $V_{CC+} = 2.7\text{ V}$ ,  $V_{CC-} = 0\text{ V}$ ,  $V_{IC} = 1\text{ V}$ ,  $V_O = 1.35\text{ V}$ , and  $R_L > 1\text{ M}\Omega$  (unless otherwise noted)

| PARAMETER |                                  | TEST CONDITIONS   | $T_A$ | MIN | TYP  | MAX | UNIT                   |
|-----------|----------------------------------|---|-------|-----|------|-----|------------------------|
| SR        | Slew rate <sup>(1)</sup>         |   | 25°C  |     | 1.7  |     | V/ $\mu$ s             |
| GBW       | Gain bandwidth product           | <sup>(2)</sup>  | 25°C  |     | 5    |     | MHz                    |
| $\Phi_m$  | Phase margin                     | <sup>(2)</sup>  | 25°C  |     | 60   |     | deg                    |
|           | Gain margin                      | <sup>(2)</sup>  | 25°C  |     | 8.6  |     | dB                     |
|           | Amplifier-to-amplifier isolation | $V_{CC+} = 5\text{ V}$ , $R_L = 100\text{ k}\Omega$ to $2.5\text{ V}$ <sup>(3)</sup>        | 25°C  |     | 135  |     | dB                     |
| $V_n$     | Equivalent input noise voltage   | $f = 1\text{ kHz}$ , $V_{IC} = 1\text{ V}$  | 25°C  |     | 45   |     | nV/ $\sqrt{\text{Hz}}$ |
| $I_n$     | Equivalent input noise current   | $f = 1\text{ kHz}$  | 25°C  |     | 0.18 |     | pA/ $\sqrt{\text{Hz}}$ |
| THD       | Total harmonic distortion        | $f = 1\text{ kHz}$ , $A_V = -2$ , $R_L = 10\text{ k}\Omega$ ,<br>$V_O = 4.1\text{ V}_{p-p}$ | 25°C  |     | 0.01 |     | %                      |

(1) Connected as voltage follower with 1-V step input. Value specified is the slower of the positive and negative slew rates.

(2) 40-dB closed-loop dc gain,  $C_L = 22\text{ pF}$

(3) Each amplifier excited in turn with 1 kHz to produce  $V_O = 3\text{ V}_{p-p}$

**5-V Electrical Characteristics**

$V_{CC+} = 5\text{ V}$ ,  $V_{CC-} = 0\text{ V}$ ,  $V_{IC} = 2\text{ V}$ ,  $V_O = 2.5\text{ V}$ , and  $R_L > 1\text{ M}\Omega$  (unless otherwise noted)

| PARAMETER      |   | TEST CONDITIONS  |            | $T_A$          | MIN            | TYP         | MAX | UNIT                         |
|----------------|---|--|------------|----------------|----------------|-------------|-----|------------------------------|
| $V_{IO}$       | Input offset voltage                                    |  |            | 25°C           |                | 1           | 6   | mV                           |
|                |   |  |            | -40°C to 125°C |                |             | 6   |                              |
| $\alpha_{VIO}$ | Average temperature coefficient of input offset voltage |  |            | 25°C           |                | 1           |     | $\mu\text{V}/^\circ\text{C}$ |
| $I_{IB}$       | Input bias current                                      |  |            | 25°C           |                | 40          | 100 | nA                           |
|                |   |  |            | -40°C to 125°C |                |             | 150 |                              |
| $I_{IO}$       | Input offset current                                    |  |            | 25°C           |                | 0.5         | 30  | nA                           |
|                |   |  |            | -40°C to 125°C |                |             | 50  |                              |
| CMRR           | Common-mode rejection ratio                             | $V_{IC} = 0\text{ to }4\text{ V}$  |            | 25°C           | 72             | 90          |     | dB                           |
|                |   |  |            | -40°C to 125°C | 70             |             |     |                              |
| $+k_{SVR}$     | Positive supply-voltage rejection ratio                 | $V_{CC+} = 1.7\text{ V to }4\text{ V}$ , $V_{CC-} = -1\text{ V}$ , $V_O = 0$ , $V_{IC} = 0$    |            | 25°C           | 75             | 85          |     | dB                           |
|                |   |  |            | -40°C to 125°C | 70             |             |     |                              |
| $-k_{SVR}$     | Negative supply-voltage rejection ratio                 | $V_{CC+} = 1.7\text{ V}$ , $V_{CC-} = -1\text{ V to }-3.3\text{ V}$ , $V_O = 0$ , $V_{IC} = 0$ |            | 25°C           | 73             | 85          |     | dB                           |
|                |   |  |            | -40°C to 125°C | 70             |             |     |                              |
| $V_{ICR}$      | Common-mode input voltage range                         | CMRR $\geq 50\text{ dB}$   |            | 25°C           | -0.2 to 4.2    | -0.3 to 4.3 |     | V                            |
| $A_V$          | Large-signal voltage amplification                      | $R_L = 600\ \Omega\text{ to }2.5\text{ V}$ , $V_O = 2.5\text{ V to }4.5\text{ V}$              | Sourcing   | 25°C           | 95             | 105         |     | dB                           |
|                |   |  |            | -40°C to 125°C | 90             |             |     |                              |
|                |   | $R_L = 600\ \Omega\text{ to }2.5\text{ V}$ , $V_O = 2.5\text{ V to }0.5\text{ V}$              | Sinking    | 25°C           | 95             | 105         |     |                              |
|                |   |  |            | -40°C to 125°C | 90             |             |     |                              |
| $V_O$          | Output swing  | $V_{CC+} = 5\text{ V}$ , $R_L = 600\ \Omega\text{ to }2.5\text{ V}$                            | High level | 25°C           | 4.75           | 4.84        |     | V                            |
|                |   |  |            | -40°C to 125°C | 4.6            |             |     |                              |
|                |   | $V_{CC+} = 5\text{ V}$ , $R_L = 2\text{ k}\Omega\text{ to }2.5\text{ V}$                       | High level | 25°C           | 4.85           | 4.9         |     |                              |
|                |   |  |            | -40°C to 125°C | 4.8            |             |     |                              |
| $I_O$          | Output current  | $V_O = 0\text{ V}$   | Sourcing   | 25°C           | 20             | 45          |     | mA                           |
|                |   |  |            | -40°C to 125°C | 15             |             |     |                              |
|                |   | $V_O = 5\text{ V}$   | Sinking    | 25°C           | 20             | 40          |     |                              |
|                |   |  |            | -40°C to 125°C | 15             |             |     |                              |
| $I_{CC}$       | Supply current  | LMV821   |            | 25°C           | 0.3            | 0.4         |     | mA                           |
|                |   |  |            |                | -40°C to 125°C |             | 0.6 |                              |
|                |   | LMV822 (both amplifiers)   |            | 25°C           | 0.5            | 0.7         |     |                              |
|                |   |  |            |                | -40°C to 125°C |             | 0.9 |                              |
|                |   | LMV824 (all four amplifiers)   |            | 25°C           | 1              | 1.3         |     |                              |
|                |   |  |            |                | -40°C to 125°C |             | 1.5 |                              |

**5-V Electrical Characteristics (continued)**
 $V_{CC+} = 5\text{ V}$ ,  $V_{CC-} = 0\text{ V}$ ,  $V_{IC} = 2\text{ V}$ ,  $V_O = 2.5\text{ V}$ , and  $R_L > 1\text{ M}\Omega$  (unless otherwise noted)

| PARAMETER |                                  | TEST CONDITIONS   | $T_A$ | MIN | TYP  | MAX | UNIT                   |
|-----------|----------------------------------|---|-------|-----|------|-----|------------------------|
| SR        | Slew rate                        | $V_{CC+} = 5\text{ V}^{(1)}$  | 25°C  | 1.4 | 1.9  |     | V/ $\mu$ s             |
| GBW       | Gain bandwidth product           | <sup>(2)</sup>  | 25°C  |     | 5.5  |     | MHz                    |
| $\Phi_m$  | Phase margin                     | <sup>(2)</sup>  | 25°C  |     | 64.2 |     | deg                    |
|           | Gain margin                      | <sup>(2)</sup>  | 25°C  |     | 8.7  |     | dB                     |
|           | Amplifier-to-amplifier isolation | $V_{CC+} = 5\text{ V}$ , $R_L = 100\text{ k}\Omega$ to $2.5\text{ V}^{(3)}$                 | 25°C  |     | 135  |     | dB                     |
| $V_n$     | Equivalent input noise voltage   | $f = 1\text{ kHz}$ , $V_{IC} = 1\text{ V}$  | 25°C  |     | 42   |     | nV/ $\sqrt{\text{Hz}}$ |
| $I_n$     | Equivalent input noise current   | $f = 1\text{ kHz}$  | 25°C  |     | 0.2  |     | pA/ $\sqrt{\text{Hz}}$ |
| THD       | Total harmonic distortion        | $f = 1\text{ kHz}$ , $A_V = -2$ , $R_L = 10\text{ k}\Omega$ ,<br>$V_O = 4.1\text{ V}_{p-p}$ | 25°C  |     | 0.01 |     | %                      |

- (1) Connected as voltage follower with 3-V step input. Value specified is the slower of the positive and negative slew rates.
- (2) 40-dB closed-loop dc gain,  $C_L = 22\text{ pF}$
- (3) Each amplifier excited in turn with 1 kHz to produce  $V_O = 3\text{ V}_{p-p}$

**TYPICAL CHARACTERISTICS**

$T_A = 25^\circ\text{C}$ ,  $V_{CC+} = 5\text{-V}$  Single Supply (Unless Otherwise Noted)

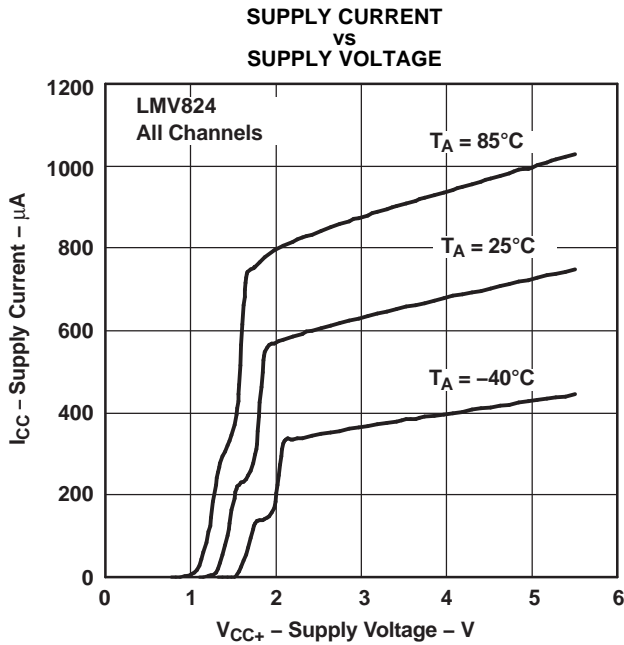

Figure 1.

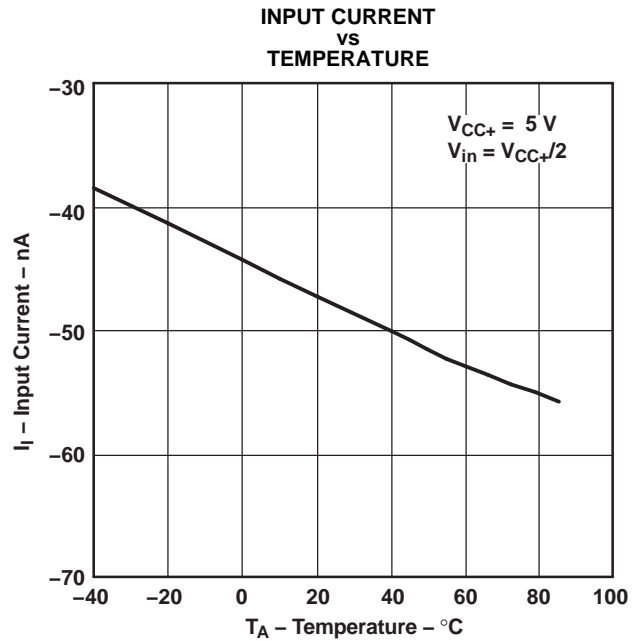

Figure 2.

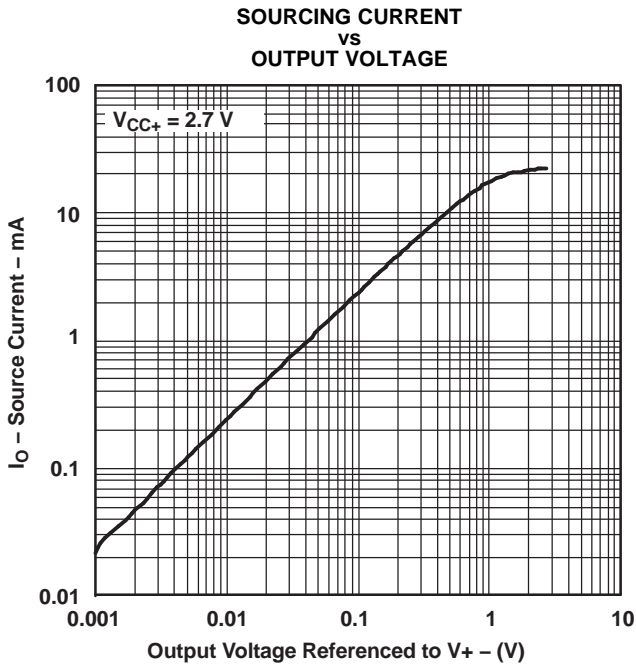

Figure 3.

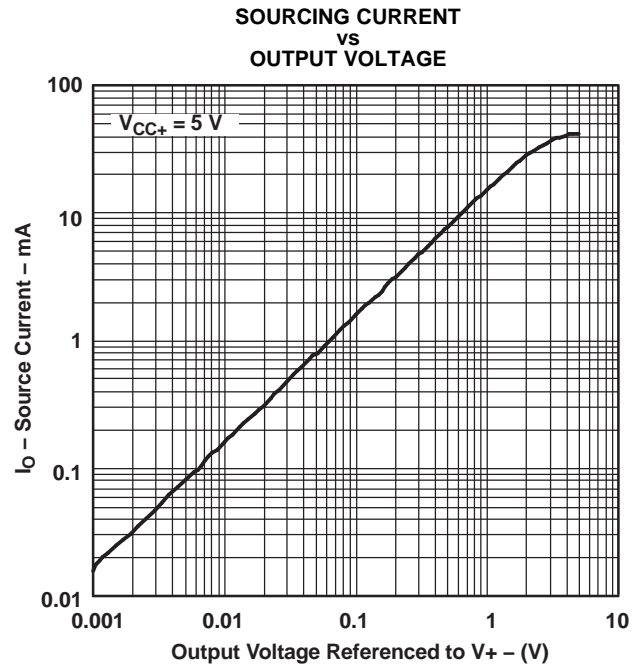

Figure 4.



TYPICAL CHARACTERISTICS (continued)

T<sub>A</sub> = 25°C, V<sub>CC+</sub> = 5-V Single Supply (Unless Otherwise Noted)

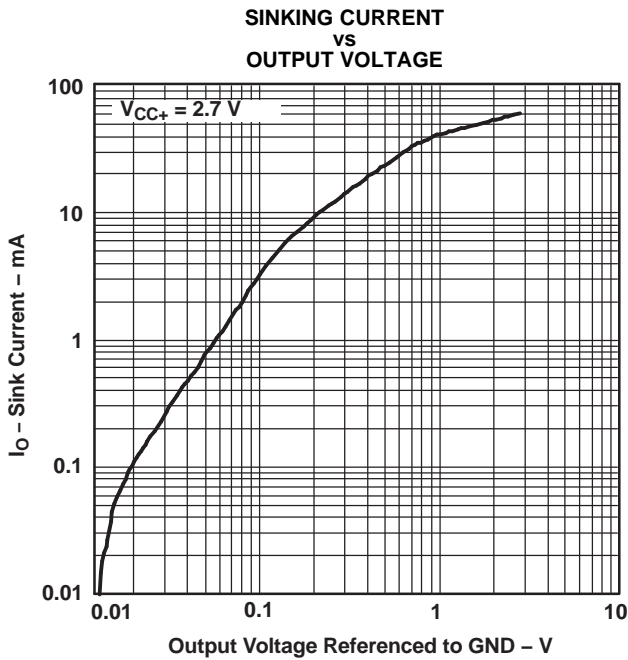

Figure 5.

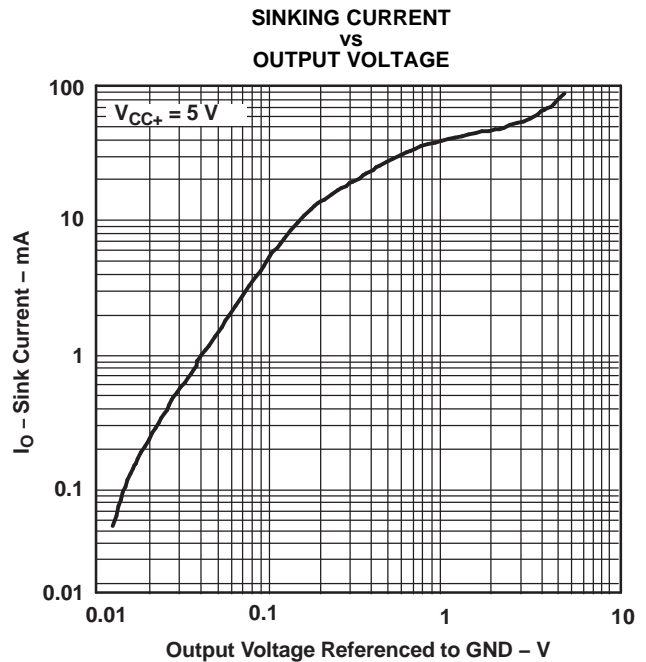

Figure 6.

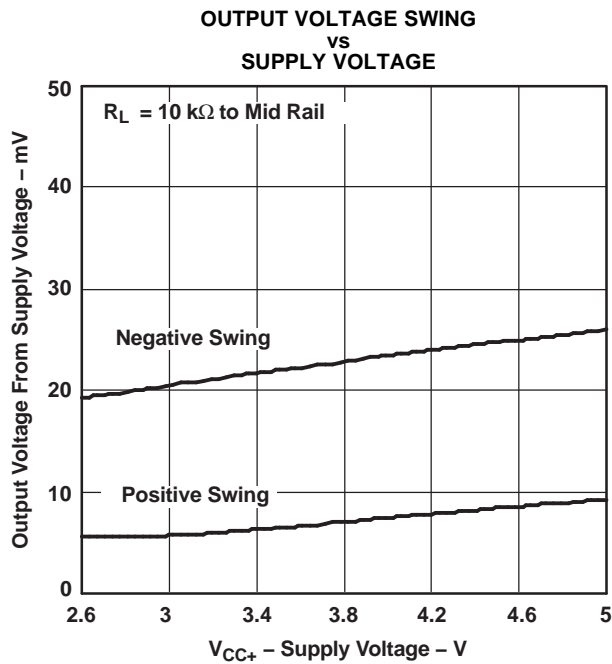

Figure 7.

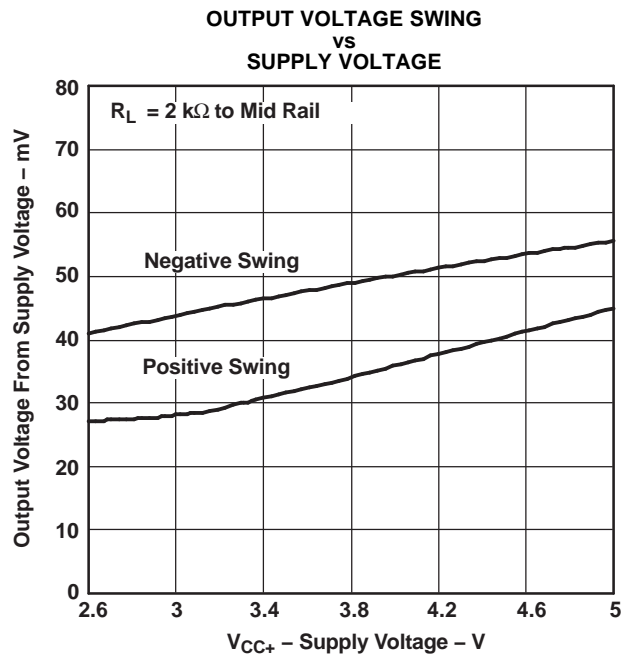

Figure 8.

**TYPICAL CHARACTERISTICS (continued)**

$T_A = 25^\circ\text{C}$ ,  $V_{CC+} = 5\text{-V}$  Single Supply (Unless Otherwise Noted)

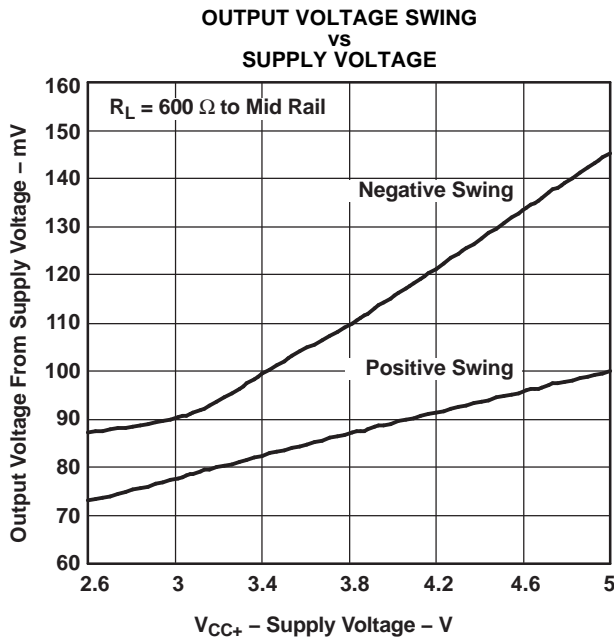

Figure 9.

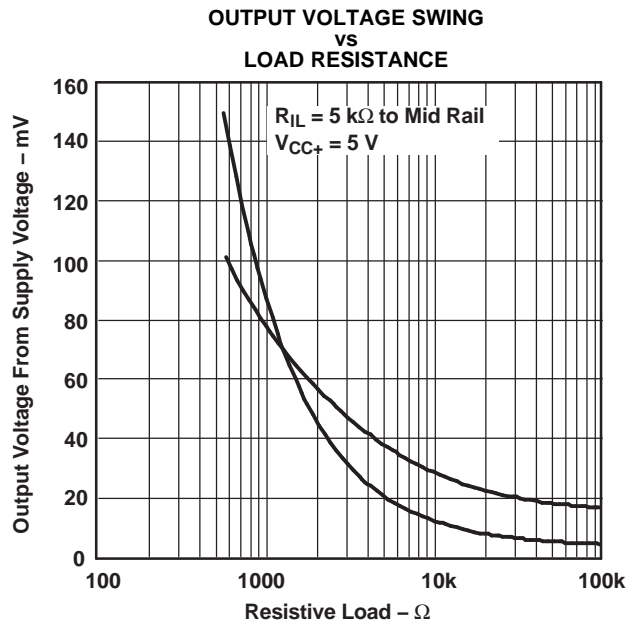

Figure 10.

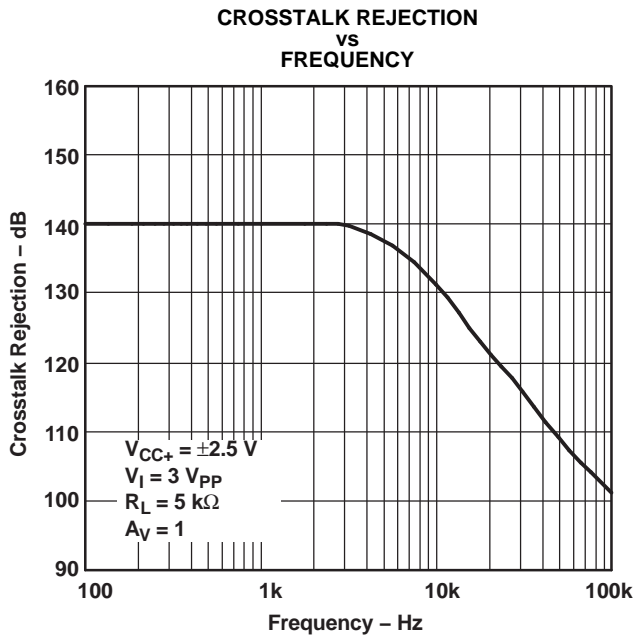

Figure 11.

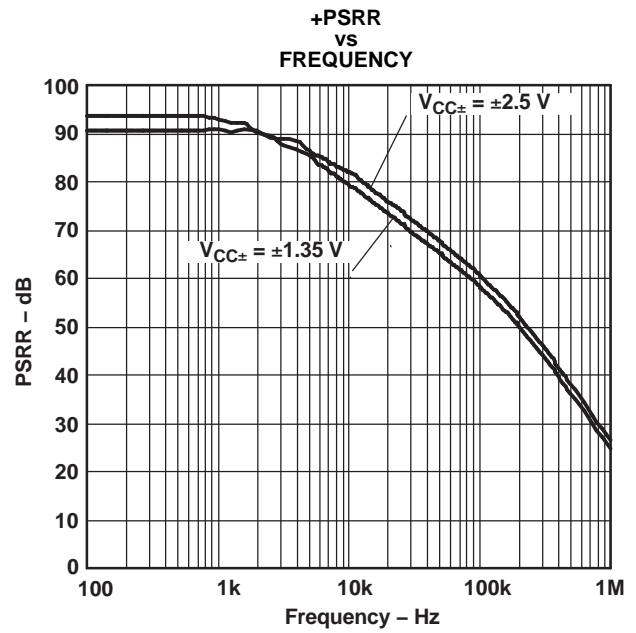
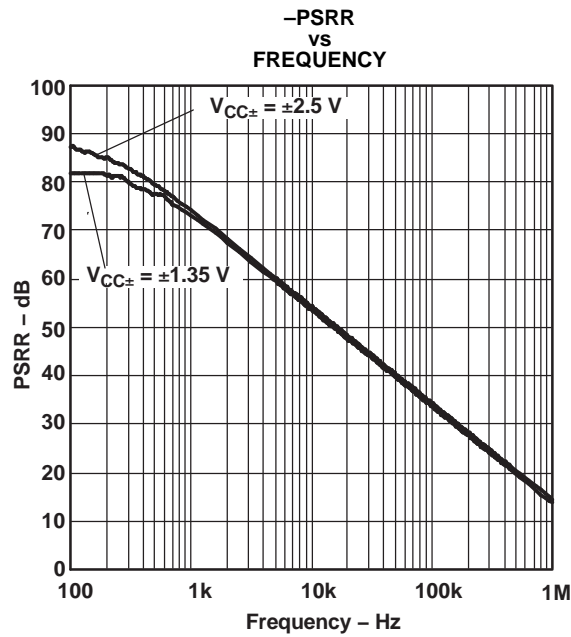

Figure 12.

TYPICAL CHARACTERISTICS (continued)

T<sub>A</sub> = 25°C, V<sub>CC+</sub> = 5-V Single Supply (Unless Otherwise Noted)



GAIN AND PHASE MARGIN  
vs  
FREQUENCY

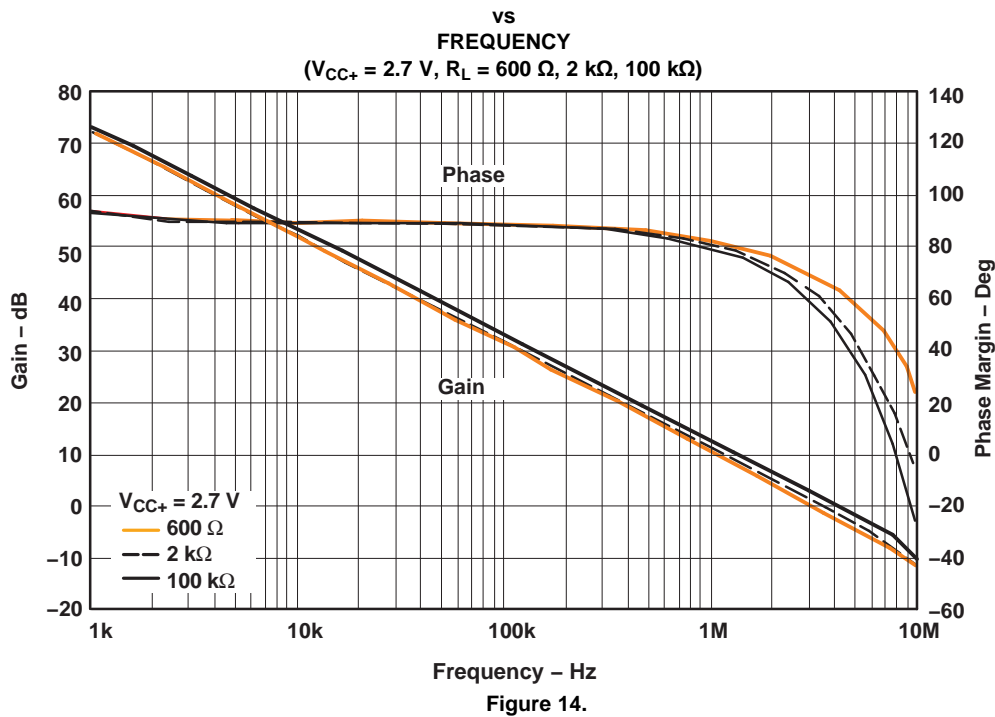

**TYPICAL CHARACTERISTICS (continued)**

$T_A = 25^\circ\text{C}$ ,  $V_{CC+} = 5\text{-V}$  Single Supply (Unless Otherwise Noted)

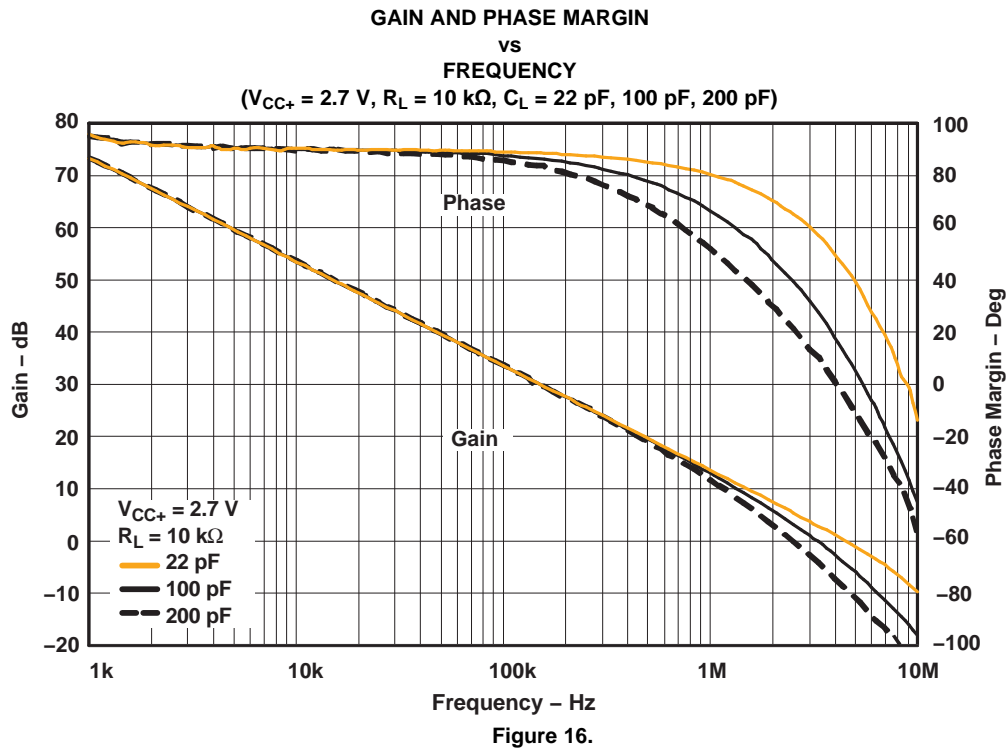
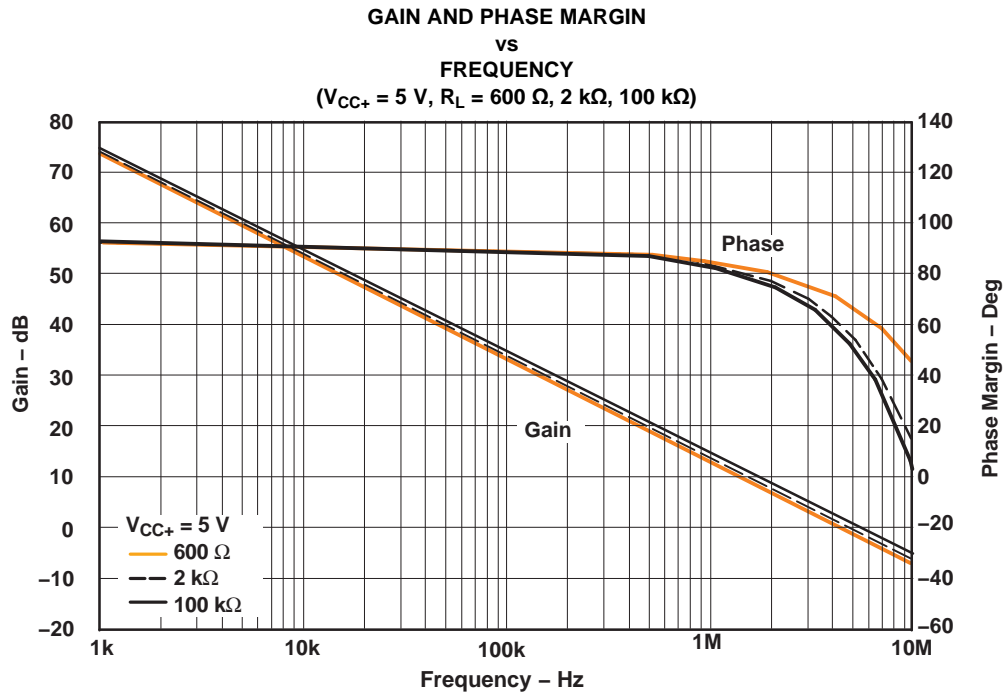

TYPICAL CHARACTERISTICS (continued)

T<sub>A</sub> = 25°C, V<sub>CC+</sub> = 5-V Single Supply (Unless Otherwise Noted)

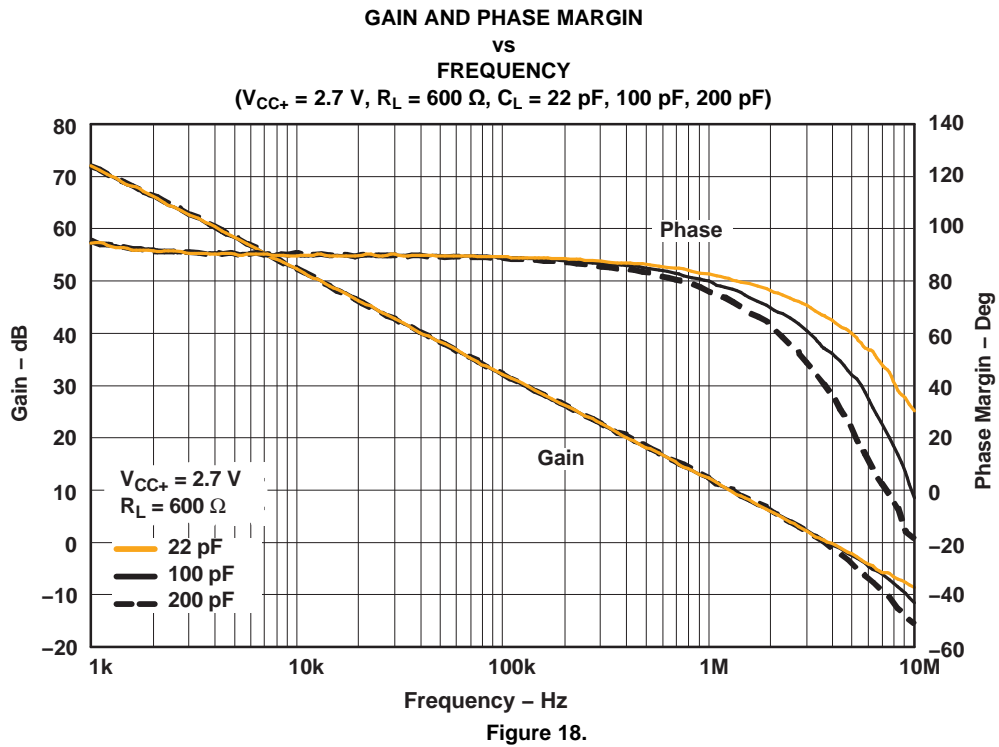
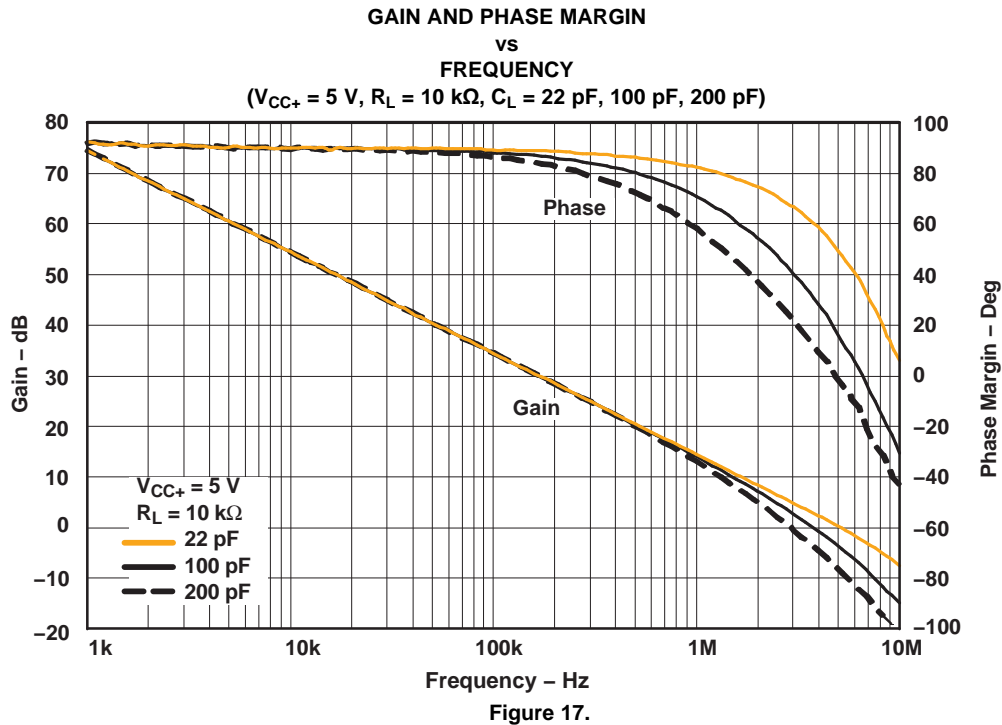

**TYPICAL CHARACTERISTICS (continued)**

$T_A = 25^\circ\text{C}$ ,  $V_{CC+} = 5\text{-V}$  Single Supply (Unless Otherwise Noted)

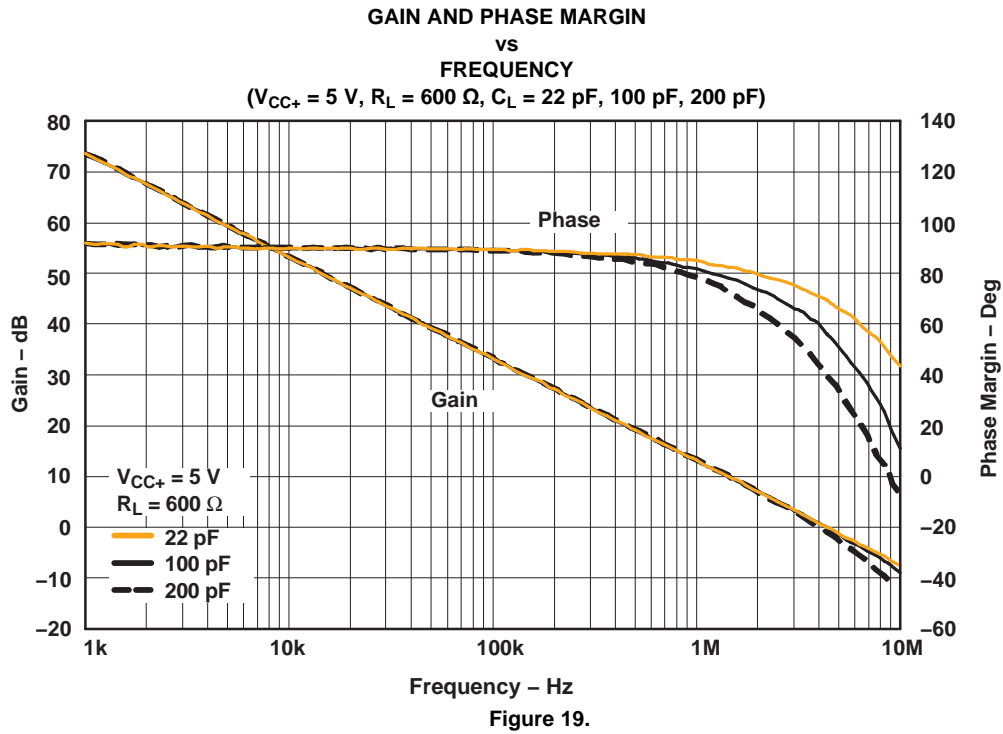

**PACKAGING INFORMATION**

| Orderable Device | Status <sup>(1)</sup> | Package Type | Package Drawing | Pins | Package Qty | Eco Plan <sup>(2)</sup> | Lead/Ball Finish | MSL Peak Temp <sup>(3)</sup> |
|------------------|-----------------------|--------------|-----------------|------|-------------|-------------------------|------------------|------------------------------|
| LMV821QDBVRQ1    | ACTIVE                | SOT-23       | DBV             | 5    | 3000        | Green (RoHS & no Sb/Br) | CU NIPDAU        | Level-1-260C-UNLIM           |
| LMV822QDGKRQ1    | ACTIVE                | MSOP         | DGK             | 8    | 2500        | Green (RoHS & no Sb/Br) | Call TI          | Level-1-260C-UNLIM           |

<sup>(1)</sup> The marketing status values are defined as follows:

**ACTIVE:** Product device recommended for new designs.

**LIFEBUY:** TI has announced that the device will be discontinued, and a lifetime-buy period is in effect.

**NRND:** Not recommended for new designs. Device is in production to support existing customers, but TI does not recommend using this part in a new design.

**PREVIEW:** Device has been announced but is not in production. Samples may or may not be available.

**OBsolete:** TI has discontinued the production of the device.

<sup>(2)</sup> Eco Plan - The planned eco-friendly classification: Pb-Free (RoHS), Pb-Free (RoHS Exempt), or Green (RoHS & no Sb/Br) - please check <http://www.ti.com/productcontent> for the latest availability information and additional product content details.

**TBD:** The Pb-Free/Green conversion plan has not been defined.

**Pb-Free (RoHS):** TI's terms "Lead-Free" or "Pb-Free" mean semiconductor products that are compatible with the current RoHS requirements for all 6 substances, including the requirement that lead not exceed 0.1% by weight in homogeneous materials. Where designed to be soldered at high temperatures, TI Pb-Free products are suitable for use in specified lead-free processes.

**Pb-Free (RoHS Exempt):** This component has a RoHS exemption for either 1) lead-based flip-chip solder bumps used between the die and package, or 2) lead-based die adhesive used between the die and leadframe. The component is otherwise considered Pb-Free (RoHS compatible) as defined above.

**Green (RoHS & no Sb/Br):** TI defines "Green" to mean Pb-Free (RoHS compatible), and free of Bromine (Br) and Antimony (Sb) based flame retardants (Br or Sb do not exceed 0.1% by weight in homogeneous material)

<sup>(3)</sup> MSL, Peak Temp. -- The Moisture Sensitivity Level rating according to the JEDEC industry standard classifications, and peak solder temperature.

**Important Information and Disclaimer:**The information provided on this page represents TI's knowledge and belief as of the date that it is provided. TI bases its knowledge and belief on information provided by third parties, and makes no representation or warranty as to the accuracy of such information. Efforts are underway to better integrate information from third parties. TI has taken and continues to take reasonable steps to provide representative and accurate information but may not have conducted destructive testing or chemical analysis on incoming materials and chemicals. TI and TI suppliers consider certain information to be proprietary, and thus CAS numbers and other limited information may not be available for release.

In no event shall TI's liability arising out of such information exceed the total purchase price of the TI part(s) at issue in this document sold by TI to Customer on an annual basis.

**OTHER QUALIFIED VERSIONS OF LMV821-Q1, LMV822-Q1 :**

- Catalog: [LMV821](#), [LMV822](#)

NOTE: Qualified Version Definitions:

- Catalog - TI's standard catalog product

DBV (R-PDSO-G5)

PLASTIC SMALL-OUTLINE PACKAGE



- NOTES:
- A. All linear dimensions are in millimeters.
  - B. This drawing is subject to change without notice.
  - C. Body dimensions do not include mold flash or protrusion. Mold flash and protrusion shall not exceed 0.15 per side.
  - D. Falls within JEDEC MO-178 Variation AA.



DGK (S-PDSO-G8)

PLASTIC SMALL-OUTLINE PACKAGE

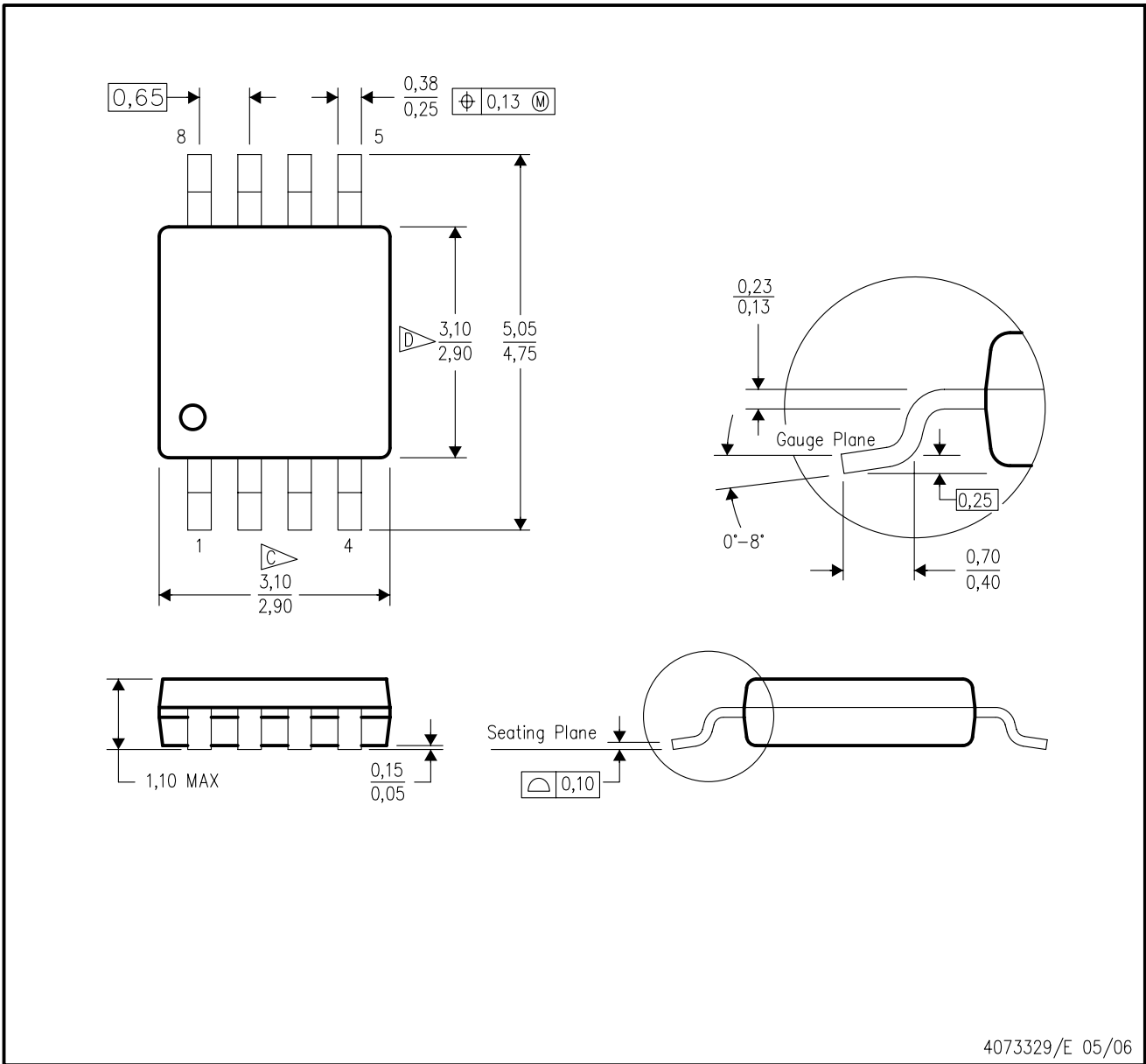

- NOTES:
- A. All linear dimensions are in millimeters.
  - B. This drawing is subject to change without notice.
  - C. Body length does not include mold flash, protrusions, or gate burrs. Mold flash, protrusions, or gate burrs shall not exceed 0.15 per end.
  - D. Body width does not include interlead flash. Interlead flash shall not exceed 0.50 per side.
  - E. Falls within JEDEC MO-187 variation AA, except interlead flash.

## IMPORTANT NOTICE

Texas Instruments Incorporated and its subsidiaries (TI) reserve the right to make corrections, modifications, enhancements, improvements, and other changes to its products and services at any time and to discontinue any product or service without notice. Customers should obtain the latest relevant information before placing orders and should verify that such information is current and complete. All products are sold subject to TI's terms and conditions of sale supplied at the time of order acknowledgment.

TI warrants performance of its hardware products to the specifications applicable at the time of sale in accordance with TI's standard warranty. Testing and other quality control techniques are used to the extent TI deems necessary to support this warranty. Except where mandated by government requirements, testing of all parameters of each product is not necessarily performed.

TI assumes no liability for applications assistance or customer product design. Customers are responsible for their products and applications using TI components. To minimize the risks associated with customer products and applications, customers should provide adequate design and operating safeguards.

TI does not warrant or represent that any license, either express or implied, is granted under any TI patent right, copyright, mask work right, or other TI intellectual property right relating to any combination, machine, or process in which TI products or services are used. Information published by TI regarding third-party products or services does not constitute a license from TI to use such products or services or a warranty or endorsement thereof. Use of such information may require a license from a third party under the patents or other intellectual property of the third party, or a license from TI under the patents or other intellectual property of TI.

Reproduction of TI information in TI data books or data sheets is permissible only if reproduction is without alteration and is accompanied by all associated warranties, conditions, limitations, and notices. Reproduction of this information with alteration is an unfair and deceptive business practice. TI is not responsible or liable for such altered documentation. Information of third parties may be subject to additional restrictions.

Resale of TI products or services with statements different from or beyond the parameters stated by TI for that product or service voids all express and any implied warranties for the associated TI product or service and is an unfair and deceptive business practice. TI is not responsible or liable for any such statements.

TI products are not authorized for use in safety-critical applications (such as life support) where a failure of the TI product would reasonably be expected to cause severe personal injury or death, unless officers of the parties have executed an agreement specifically governing such use. Buyers represent that they have all necessary expertise in the safety and regulatory ramifications of their applications, and acknowledge and agree that they are solely responsible for all legal, regulatory and safety-related requirements concerning their products and any use of TI products in such safety-critical applications, notwithstanding any applications-related information or support that may be provided by TI. Further, Buyers must fully indemnify TI and its representatives against any damages arising out of the use of TI products in such safety-critical applications.

TI products are neither designed nor intended for use in military/aerospace applications or environments unless the TI products are specifically designated by TI as military-grade or "enhanced plastic." Only products designated by TI as military-grade meet military specifications. Buyers acknowledge and agree that any such use of TI products which TI has not designated as military-grade is solely at the Buyer's risk, and that they are solely responsible for compliance with all legal and regulatory requirements in connection with such use.

TI products are neither designed nor intended for use in automotive applications or environments unless the specific TI products are designated by TI as compliant with ISO/TS 16949 requirements. Buyers acknowledge and agree that, if they use any non-designated products in automotive applications, TI will not be responsible for any failure to meet such requirements.

Following are URLs where you can obtain information on other Texas Instruments products and application solutions:

### Products

|                             |  |
|-----------------------------|--|
| Amplifiers                  | <a href="http://amplifier.ti.com">amplifier.ti.com</a>             |
| Data Converters             | <a href="http://dataconverter.ti.com">dataconverter.ti.com</a>     |
| DSP                         | <a href="http://dsp.ti.com">dsp.ti.com</a>                         |
| Clocks and Timers           | <a href="http://www.ti.com/clocks">www.ti.com/clocks</a>           |
| Interface                   | <a href="http://interface.ti.com">interface.ti.com</a>             |
| Logic                       | <a href="http://logic.ti.com">logic.ti.com</a>                     |
| Power Mgmt                  | <a href="http://power.ti.com">power.ti.com</a>                     |
| Microcontrollers            | <a href="http://microcontroller.ti.com">microcontroller.ti.com</a> |
| RFID                        | <a href="http://www.ti-rfid.com">www.ti-rfid.com</a>               |
| RF/IF and ZigBee® Solutions | <a href="http://www.ti.com/lprf">www.ti.com/lprf</a>               |

### Applications

|                    |  |
|--------------------|--|
| Audio              | <a href="http://www.ti.com/audio">www.ti.com/audio</a>                   |
| Automotive         | <a href="http://www.ti.com/automotive">www.ti.com/automotive</a>         |
| Broadband          | <a href="http://www.ti.com/broadband">www.ti.com/broadband</a>           |
| Digital Control    | <a href="http://www.ti.com/digitalcontrol">www.ti.com/digitalcontrol</a> |
| Medical            | <a href="http://www.ti.com/medical">www.ti.com/medical</a>               |
| Military           | <a href="http://www.ti.com/military">www.ti.com/military</a>             |
| Optical Networking | <a href="http://www.ti.com/opticalnetwork">www.ti.com/opticalnetwork</a> |
| Security           | <a href="http://www.ti.com/security">www.ti.com/security</a>             |
| Telephony          | <a href="http://www.ti.com/telephony">www.ti.com/telephony</a>           |
| Video & Imaging    | <a href="http://www.ti.com/video">www.ti.com/video</a>                   |
| Wireless           | <a href="http://www.ti.com/wireless">www.ti.com/wireless</a>             |

Mailing Address: Texas Instruments, Post Office Box 655303, Dallas, Texas 75265  
Copyright © 2008, Texas Instruments Incorporated